

Installation Manual

MHE Intelligent Fast Charging Systems DVS100/DVS150 CEC

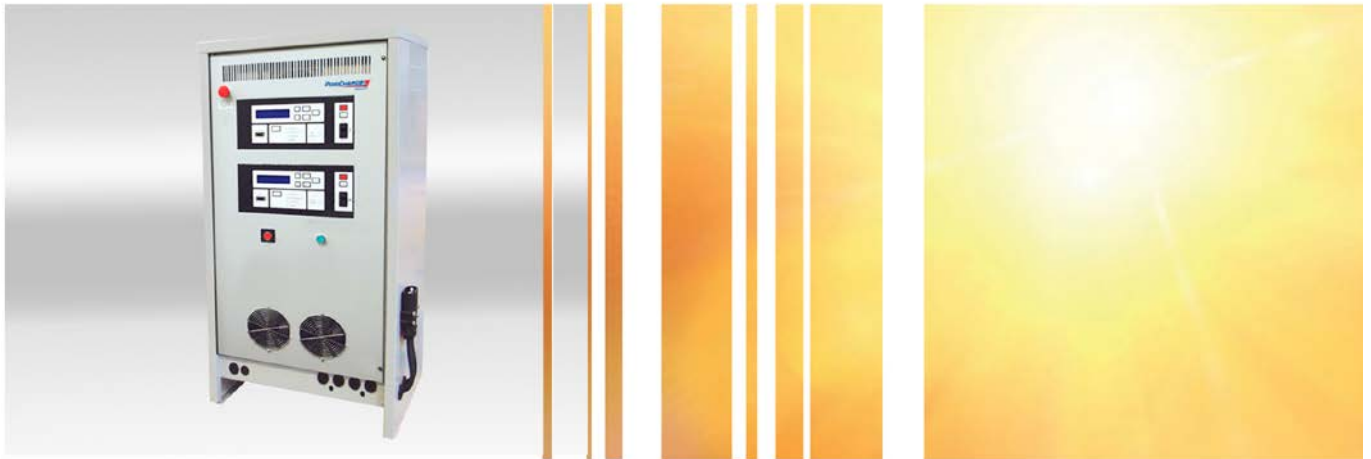

North America

© 2019 Webasto Charging Systems, Inc. All rights reserved.

PosiCharge™ systems is a product line of Webasto Charging Systems, Inc. Webasto and the Webasto logo are trademarks of Webasto Charging Systems, Inc. Corporate names, trademarks, registered trademarks, service marks, symbols, and logos stated herein are property of their respective companies. Specifications are subject to change without notice. Images of the power cycling and test systems are representative; production models may vary. No portion of these materials may be duplicated, used, or disclosed without prior written permission from Webasto Charging Systems, Inc.

Disclaimer: this manual includes the latest information available at the time of printing. Webasto Charging Systems, Inc. Reserves the right to make changes to this manual and/or product without further notice. Changes or modifications to this product not completed by an authorized service provider could void the product warranty.

These commodities, technology or software were exported from the United States in accordance with the Export Administration Regulations. Diversion contrary to US law prohibited.

PosiCharge™ systems, a product line of Webasto Charging Systems, Inc..
1.866.767.4242 | info@posicharge.com | [@posicharge](https://www.posicharge.com) | [posicharge.com](https://www.posicharge.com)
© 2019 Webasto Charging Systems Inc.

Table of Contents

1	Getting Started	4
2	Safety Precautions – Read before using.....	4
2.1	Symbol usage.....	4
2.2	Cautions and Warnings.....	4
2.3	Technical Support.....	5
2.4	List of Webasto-Provided Equipment.....	5
2.5	ESD Precautions	6
3	System Description.....	6
4	Installation.....	6
4.1	Preparation	6
4.2	Equipment Access.....	7
4.3	Wiring	7
4.3.1	General Guidelines.....	7
4.3.2	Ground Wire	7
4.3.3	Charging Cables / Cable Management System	7
4.3.4	Grounding	7
4.3.5	Hardware	7
4.4	Physical Installation.....	8
4.5	Connecting AC (Utility) Power.....	11
4.6	DC Output Cable Installation.....	15
4.7	Checklist.....	16

List of Tables

Table 4-1	Utility and Wiring Information.....	11
Table 4-2	Output Characteristics for DVS	12

List of Figures

Figure 3-	1 Components of the Charging System	6
Figure 4-1	DVS-100 and DVS-150 Installation.....	9
Figure 4-2	Bolt Pattern for DVS-100 and DVS-150 Installation (Dimensions in Inches).....	10
Figure 4-3	DVS-100 and DVS-150 Location of Transformer Taps Terminal Block.....	13
Figure 4-4	DVS-100 and DVS150 Location of Chassis Ground Connector	13
Figure 4-5	Dual Voltage Systems (480/600VAC) - Location of Auxiliary Transformer Terminal Block.....	14
Figure 4-6	DC Output Cable Installation.....	15

1 Getting Started

Before you begin, take the time to familiarize yourself with the Cautions in Section 2, and read the installation instructions in Section 4 completely before you install your new DVS.

To get your system up and running quickly perform the following steps:



1. Ensure the DVS siting requirements are followed. (Section 4.4)
2. Connect the 3 phase utility power to the DVS, and apply power to the DVS. (Section 4.5)
3. Install the BMID on battery pack. (Section 4)
4. Once the BMID is installed, the battery pack may be connected to the charger.
5. If your BMID does not come pre-configured, you will need to initialize the new BMID. (Refer to BMID programming Manual, P/N document #06701)
6. Once the BMID has been properly programmed, the battery pack is ready to begin charging.

2 Safety Precautions – Read before using



The DVS is designed with the safety of the user as the highest priority. Installation must comply with all local codes, and the following safety precautions must be read and observed.

2.1 Symbol usage

Throughout this manual, take special note of the information marked with the following symbols:

 DANGER	Contains information about safety practices necessary to prevent personal injury or death.
 WARNING	Contains information about safety practices necessary to prevent fire or equipment overheating.
 DANGER	Contains information to prevent shock hazard or possible damage to the equipment during installation and service.

NOTE: Offers helpful information for installation or usage, but does not contain personnel or equipment safety related information.

 CAUTION BEFORE YOU BEGIN	<ul style="list-style-type: none"> • Read all instructions and cautionary markings on the Industrial PosiCharge™ (DVS) Assembly. • Make sure you also read the IMPORTANT SAFETY INSTRUCTIONS below. • Be sure to leave these instructions with the installed unit for future reference. • Only qualified personnel should install, use or service this charger. • Read and understand these Manufacturer's instructions and your employer's safety practices manual.
 DANGER	<p>ELECTRIC SHOCK CAN KILL: Touching live electrical parts can cause fatal shocks or severe burns. The battery terminals are always electrically live, and the output circuit is live whenever the battery is connected or being charged. The input power circuitry and internal circuits are live whenever input power is on. An incorrectly installed or improperly grounded charger is a hazard.</p>

2.2 Cautions and Warnings

- The unit must be grounded properly with a grounding conductor of size equal to or larger than that recommended by local electrical codes or the installation section of this manual.
- Do not touch the uninsulated portion of the output battery connector or an uninsulated battery terminal.
- Only qualified service personnel may remove the front or back panels on the DVS. There are no user serviceable parts inside. Refer all servicing to qualified service personnel. Opening the system or attempted installation or repair by other than qualified service personnel voids the warranty.

- Disconnect battery charger from input power and battery connections before installing or servicing. Lockout/Tagout input power according to OSHA 29 CFR 1910.147.
- Do not expose to rain or perform installation/service/repair work when in standing water.
- A charge can be stopped by disconnecting the output cable connector or by pressing the stop button on the front panel. The DVS is designed to automatically stop a charge event to prevent arcing or burning of the charger connections in the event of a hot disconnect.
- The charging cables must be sized for the full rated current of the DVS, and inspected frequently for wear, cuts and abrasion. Do not use worn, damaged, undersized, or poorly spliced cable.
- The DVS charging connector is subject to normal wear and tear, and may be damaged by misuse or abuse. Frequently inspect the connector for cracking, pitting of contacts, fraying of wires, or signs of connector fatigue. A damaged charging connector should be replaced immediately.

 WARNING	<p>OSHA INSTRUCTION STD 1-11.4 OCTOBER 30, 1978 4. Action</p> <p>“Battery charging” areas where power industrial truck batteries are charged only—no maintenance is performed, batteries are not removed from the trucks and no electrolyte is present in the area—are not subject to the requirements of 29 CFR 1910.178 (g) (2). The charging areas shall be in compliance with 29 CFR 1910.178 (g) (1), (8), (9), (10), (11) and (12). Personal protective equipment shall be used when and where required.</p>
--	--

- Do not install or place unit on, over or near combustible surfaces.
- Do not install unit near flammables.
- Do not block air intake or exhaust.
- Ensure that the Battery Monitor/Identifier (BMID) is properly installed according to the BMID installation instructions.
- Do not overload building wiring - be sure power supply system is properly sized, rated and protected to handle this unit. Use only on circuits provided with the minimum wire size specified in the installation section.
- Protective bollards or Armco barriers should be installed where charging equipment location is subject to damage from vehicle activity.
- Do not install unit where it will be exposed to direct sunlight.
- To avoid shock hazard, only install cables approved by PosiCharge™ for indoor use.
- Do not subject the cable or coupler to damage or stress. Do not step on the coupler cable.
- Do not hang from the coupler cable.
- Do not disassemble the DVS.
- Follow the National Electrical Code (NEC) and local codes. NEC and local codes take precedence. If any instructions in this manual conflict with NEC or local codes, contact Webasto Charging Systems, Inc. for further information.

2.3 Technical Support

This manual is intended to provide an authorized, fully trained installation technician with the information and guidance necessary to safely install the DVS equipment. For assistance contact PosiCharge™ Customer Support at:

(866) 767-4242
E-mail: info@posicharge.com

2.4 List of Webasto-Provided Equipment

Equipment Description	Quantity	Model No.	Comments
DVS	1	DVS100 480/600VAC DVS150 480/600VAC	One of these Products supplied
Cable, Assy, BMID Comm	2	Contact Tech Support	Optional
Kit, Installation, BMID, MVS/DVS/ELT, EURO, W/Connector	2	Contact Tech Support	Optional
Assy, BMID, 24V, 36-48V, 72-80V, Generic, UL	2	Contact Tech Support	Optional
Cable Management Pole Assy (48")	2	07233	Optional
Cable Management Pole (48") and Pogo Stick	2	09258	Optional
Cable Management Pole (40") and Pogo Stick	2	11752	Optional

2.5 ESD Precautions

Electronic circuits are sensitive to damage from electrostatic discharge. Persons servicing this equipment should be trained in proper techniques for avoiding ESD damage to electronic circuits. As a minimum, when handling circuit boards, wear an appropriate ESD wrist strap connected to the equipment chassis.

3 System Description

The keypad and display provide the user interface to the charger. The display constantly updates the charger and battery status, and allows access to the programming menus through the keypad. Four (4) status LEDs indicate when a charge is in progress, at 80% complete, fully charged, or in equalization. A fault/warning LED serves to alert the user to fault conditions.

The DVS works with a small monitoring device mounted on the battery called the battery monitor/identifier (BMID). As shown in Figure 3- 1, when a vehicle equipped with a BMID connects to the charger, the charger communicates with the BMID to ensure optimal charging.

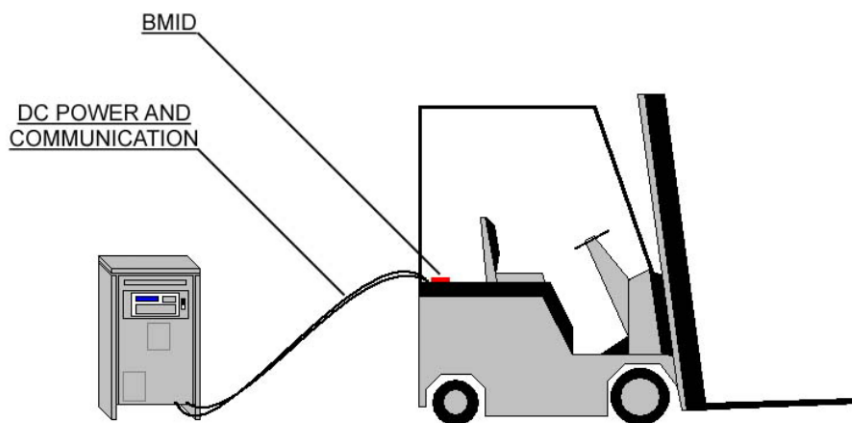



Figure 3- 1 Components of the Charging System

Typically, the battery dealer or another authorized service technician will install the BMID on the battery and configure it before delivery to the customer. BMIDs may also be configured on site through the charger front panel (see the “BMID Programming Manual”).

Many different sizes and types of industrial battery packs may be charged with the DVS. Choose the correct BMID and BMID programming for the nominal voltage and size of your pack.

	WARNING	IMPROPER INSTALLATION CAN CAUSE FIRE
---	----------------	---

4 Installation

This section outlines the requirements and procedures for installing the DVS. Read the entire section before proceeding with installation, and make sure you have read and understood the warnings in Section 2. Installation should be completed by an experienced electrician and should conform to all relevant electrical codes.

4.1 Preparation

Unpacking and Inspection

The DVS is provided fully assembled on a shipping pallet. It is surrounded by a protective shipping box. Remove the packaging and any other shipping materials prior to installation.

The following equipment is provided with each system:

- One DVS system
- DVS Installation Manual
- CD Manual

The following equipment is shipped to truck retrofit location

- Two BMID systems with related connectors
- Two BMID thermistor kit
- The “BMID Programming” Manual

NOTE: Additional connector sets and BMID kits may be purchased from your authorized DVS Dealer.

4.2 Equipment Access

Be sure to use the proper size driver bits when removing or installing screws to avoid stripping the heads. Screws should be started slowly after aligning the holes to avoid cross threading.

4.3 Wiring

4.3.1 General Guidelines

- Check utility configuration tag on DVS to make sure that rated input voltage matches local utility voltage. See Table 4-1 for details.
- See Table 4-1 for Input/Output parameters.

4.3.2 Ground Wire

- Green, or green with a yellow stripe, attached to the compression lug provided.

4.3.3 Charging Cables / Cable Management System

- To avoid shock hazard, only install cables approved by PosiCharge™ for indoor use.

 <p>DANGER</p>	<p>CABLES CARRY HIGH POWER/CURRENT Damaged cables and/or connectors can be a serious safety hazard. Cables must be secured with an approved Cable Management System. Cables are to be kept off the floor.</p> <p><u>Failure to use a Cable Management System may invalidate Product Warranty.</u></p>
---	--

4.3.4 Grounding

- DVS must be connected to an equipment-grounding conductor routed with the circuit conductors. Connections must comply with all local codes and ordinances.
- The DVS must be grounded in accordance with the Facilities Utility grounding method.
- See Table 4-1 for wiring size (AWG) and additional information.
- Use THHN or similar type, 600V, 90° C, suitable for conduit use.
- Use copper conductors only.
- Minimum ground wire size is listed. Refer to local electrical codes for reference.

4.3.5 Hardware

Manufacturer does not supply all external mounting hardware. User-supplied hardware may be needed to complete the installation.

4.4 Physical Installation

		DVS100	DVS150
	DVS Weight	531lbs	619lbs
 CAUTION	Always use appropriate equipment for handling the unit. Use a forklift of sufficient capacity to lift the unit. Do not use hooks to lift the unit. Do not tip the unit. It must be kept in a vertical position.		

The external dimensions of the DVS-100 and DVS-150 are:

- Base: 20.44 x 24.5 in (51.9 x 62.3cm)

- Height: 51.47 in (130.7cm)

Location

Choose your installation location to:

- Avoid temperature and humidity extremes.
- Minimize moisture and dust.
- Provide adequate air circulation to prevent the buildup of fumes.
- Install on a cement pad minimum 7" above surrounding curbing or walkways for water flood control, see Figure 4-1 and Figure 4-2.
- Maintain a minimum of 18" of clearance on the sides of the unit for proper ventilation.
- Maintain 36" minimum clearance on front and back for servicing as required by local codes.
- Do not install unit where it will be exposed to direct sunlight.

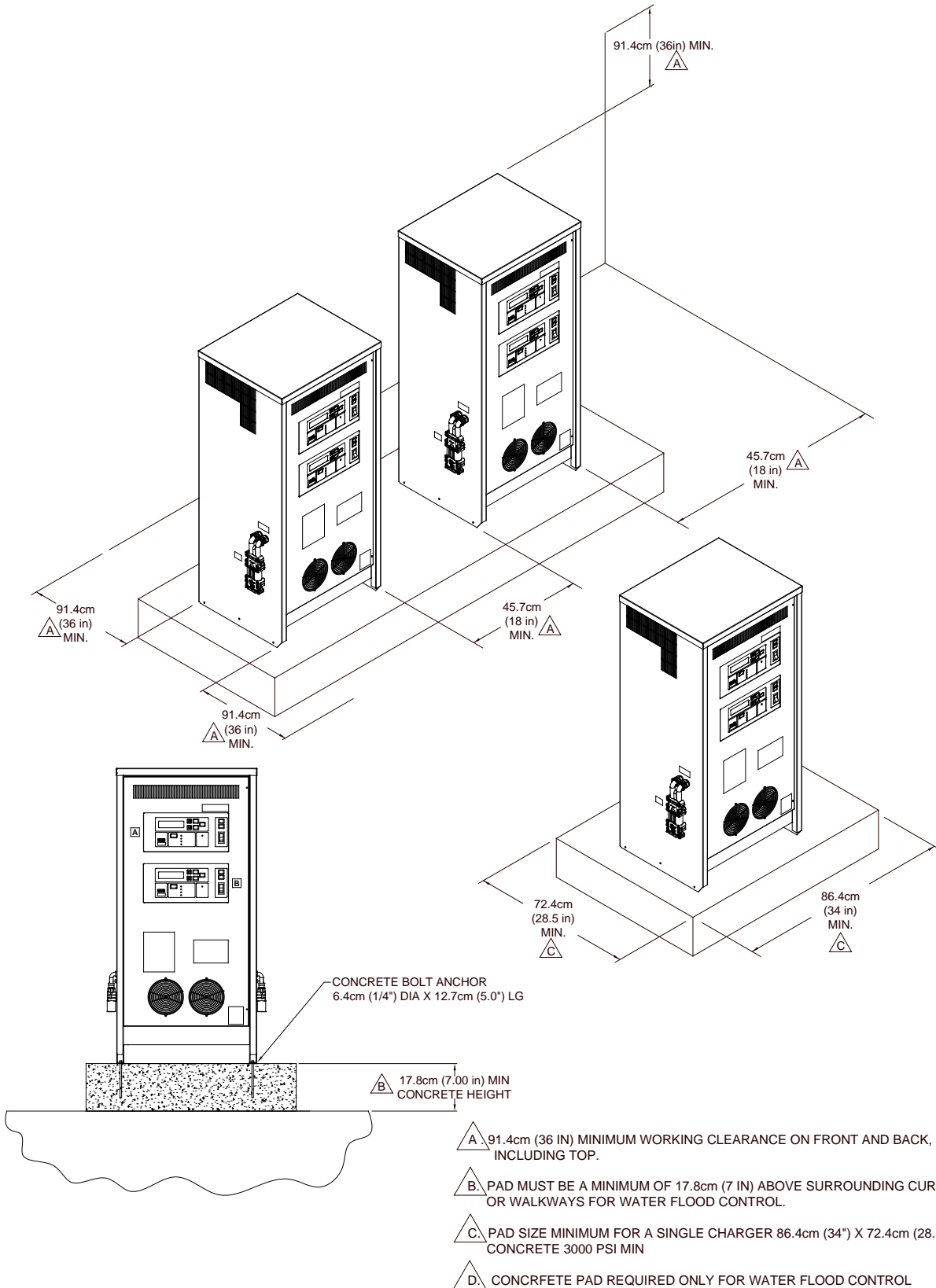

Figure 4-1 DVS-100 and DVS-150 Installation

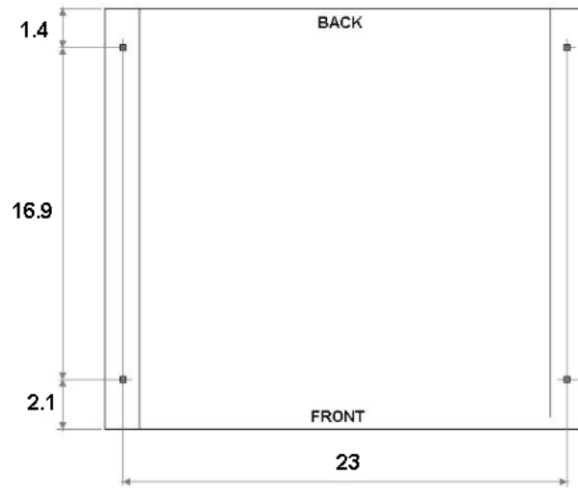





Figure 4-2 Bolt Pattern for DVS-100 and DVS-150 Installation (Dimensions in Inches)

4.5 Connecting AC (Utility) Power

 CAUTION	<p>Prior to connecting the unit to the utility ensure that:</p> <ul style="list-style-type: none"> The available grounding connection meets all state and local codes and the National Electrical Code (NEC). The main circuit breaker or other "line disconnect" device is within sight of the unit and is easily accessible to allow complete power down of the unit.
 DANGER	<p>Incorrect power wire installation, or failure to properly ground unit may result in a severe shock hazard.</p>
 CAUTION	<p>Use copper conductors only.</p>

Utility power lines to DVS must be provided from an appropriately rated utility distribution panel. The utility distribution panel must include a "branch" rated circuit breaker (CB). The CB may also be the "line disconnect" device. Utility power must be 60Hz, 3 phase, 3 wire plus ground. See Table 4-1 for information on input current, utility requirement, and cable sizes. All phase wires must be rated for the full input AC current as listed.

Table 4-1 Utility and Wiring Information

Configuration	DVS100 2X10kW	DVS100 2X10kW	DVS150 2X15kW	DVS150 2X15kW
Input voltages	480 ± 10%	600 ± 10%	480 ± 10%	600 ± 10%
Input AC Current at rated load (Amps)	28	23	40	32
Input Frequency (Hz)	60	60	60	60
Number of input Phases (Excluding Ground)	3	3	3	3
Maximum Circuit Breaker Rating (Amps)	40	30	50	40
Minimum Disconnect Switch Voltage Rating (VAC)	600	600	600	600
Minimum Inrush Current Capacity (Amps)	225A, 2 cycle start-up load	225A, 2 cycle start-up load	250A, 2 cycle start-up load	250A, 2 cycle start-up load
THD Max	35%	35%	35%	35%
Minimum Input Conductor Size (AWG)	8	10	8	8
Minimum Grounding Conductor Size (AWG)	10	10	10	10
Minimum Input Wire Terminal Torque (in-lb)	N/A	N/A	N/A	N/A
Minimum Ground Wire Terminal Torque (in-lb)	35-44	35-44	35-44	35-44
Output Cable Connector	320 Anderson Euro		320 Anderson Euro	

Reference National Electrical Code. ANSI/NFPA 70.1999

Table 4-2 Output Characteristics for DVS

Configuration	DVS100	DVS150
Max Output Power (kW)	2X10	2X15
Max Output DC Range (Volts)	16-120	16-130
Max Output DC Current (Amps)	200	300
Minimum Output Wire Size (DC BUS +, AWG)	2 X 70MM ² or 2 X 2/0	2 x 95MM ² or 2 x 3/0
Minimum Output Wire Size (DC BUS -, AWG)	2X70MM ² or 2 X 2/0	2 x 95MM ² or 2 x 3/0

Installation / Line Voltage Instructions (480VAC)

1. Remove the screws and open the front door of the DVS.
2. Locate the AC Input Terminal Block and the Chassis Ground Connector. Refer to Figures 4-3 thru 4-6.
3. Bring utility wires from the Utility Distribution Panel through conduit, and route them to the AC Input Terminal Block and the Chassis Grounding Connector. Refer to Figures 4-3 thru 4-6.
NOTE: The grounding wire should have insulation that is green or green with yellow stripe.
4. Close the front door prior to switching on the utility power.

Installation / Line Voltage Changeover Instructions (Dual voltage configuration 480/600VAC)

1. Remove the screws and open the front door of the DVS.
2. Locate the Transformer Taps Terminal Block and the (3) black wires, marked with the letters A, B, C. Refer to Figures 4-3 thru 4-6.
3. Locate the Auxiliary Transformer Input Terminal Block. Refer to Figure 4-3.
4. Refer to the label that is located above the Transformer Taps Terminal Blocks to determine if the charger is connected for available line voltage (480 or 600 VAC).
5. Bring utility wires from the Utility Distribution Panel through conduit, and route them to the AC Input Terminal Block and the Chassis Grounding Connector. Refer to Figures 4-3 thru 4-6.
NOTE: The grounding wire should have insulation that is green or green with yellow stripe.
6. Close the front door prior to switching on the utility power.

	WARNING	ENSURE GOOD ELECTRICAL CONNECTION BY TIGHTENING ALL THE SCREWS PROPERLY
---	----------------	--

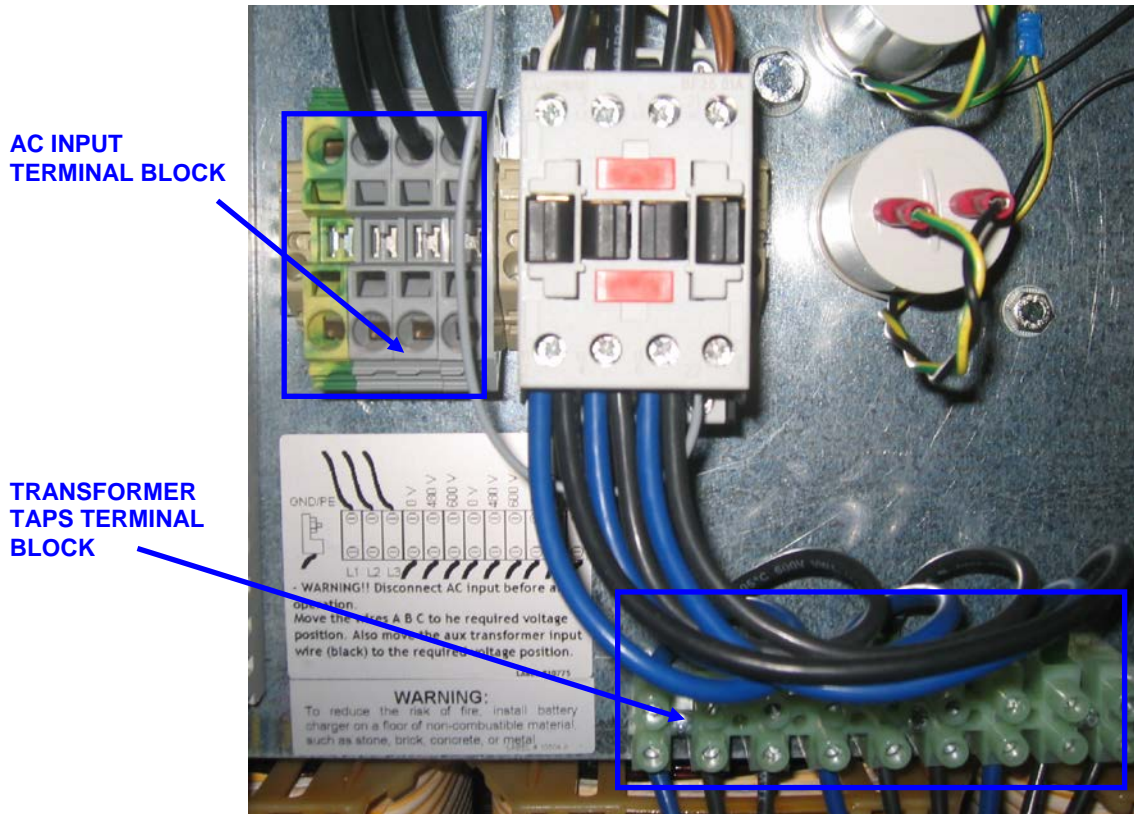

Figure 4-3 DVS-100 and DVS-150 Location of Transformer Taps Terminal Block

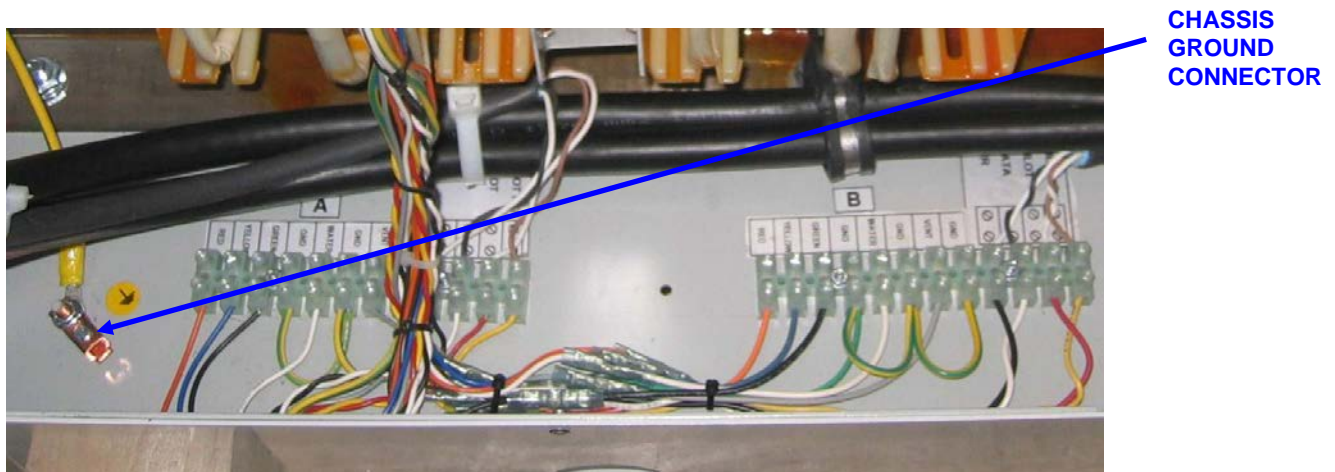

Figure 4-4 DVS-100 and DVS150 Location of Chassis Ground Connector

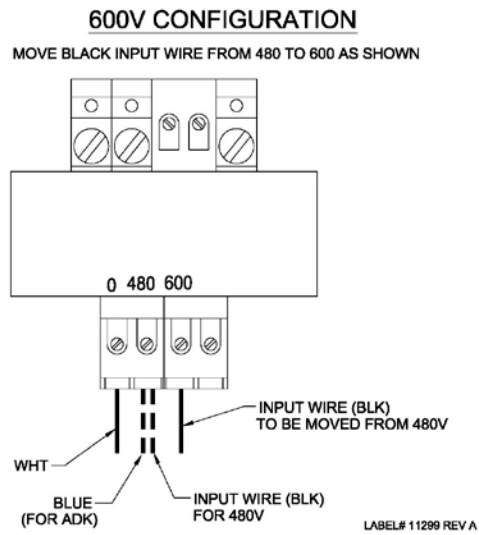

Figure 4-5 Dual Voltage Systems (480/600VAC) - Location of Auxiliary Transformer Terminal Block

Note: If the charger has an ADK transformer, the blue input wire stays on the 480V.

4.6 DC Output Cable Installation

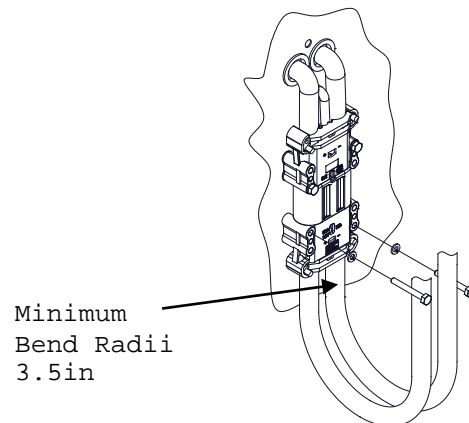

Figure 4-6 DC Output Cable Installation

To install output cable(s):

1. Install output cable(s) ensuring mounting screws and lock washers are properly installed and tightened. **Recommended torque: 8.47 Nm (75 in-lbs).**
2. A proper cable management system is required to relieve stress on the output connector mounting hardware.

**Note: 1) Do not remove connector key(s) from the connector.
2) Minimum bend radii of 3.5 in are required for the output cables.**

4.7 Checklist

DVS - INSTALLATION AND OPERATIONAL CHECKOUT				
DVS	DVS	DVS	DVS	
Serial #	Serial #	Serial #	Serial #	
_____	_____	_____	_____	
V_ _ _	V_ _ _	V_ _ _	V_ _ _	VERIFY AND RECORD SW VERSION
<input type="checkbox"/>	<input type="checkbox"/>	<input type="checkbox"/>	<input type="checkbox"/>	CHECK UNIT IS SECURELY MOUNTED
<input type="checkbox"/>	<input type="checkbox"/>	<input type="checkbox"/>	<input type="checkbox"/>	CHECK AC CIRCUIT BREAKER RATING DVS100 RATING IS 40 AAC @ 480VAC DVS100 RATING IS 30 AAC @ 600VAC DVS150 RATING IS 50 AAC @ 480VAC DVS150 RATING IS 40 AAC @ 600VAC
<input type="checkbox"/>	<input type="checkbox"/>	<input type="checkbox"/>	<input type="checkbox"/>	UTILITY CONNECTIONS PROPERLY INSTALLED WITH ALL FASTENERS TIGHTENED: CHECK AC TERMINAL BLOCK CHECK CHASSIS GND CONNECTOR CHECK INPUT AND OUTPUT WIRES OF AC CONTACTOR ARE SECURE
<input type="checkbox"/>	<input type="checkbox"/>	<input type="checkbox"/>	<input type="checkbox"/>	ALL DC BUS CONNECTIONS PROPERLY INSTALLED WITH ALL FASTENERS TIGHTENED: CHECK DC OUTPUT NEGATIVE CHECK DC OUTPUT POSITIVE CHECK DC FUSE CHECK SHUNT RESISTOR
<input type="checkbox"/>	<input type="checkbox"/>	<input type="checkbox"/>	<input type="checkbox"/>	CHECK OUTPUT CABLE STRAIN RELIEFS ARE SECURED
<input type="checkbox"/>	<input type="checkbox"/>	<input type="checkbox"/>	<input type="checkbox"/>	BMID COMMUNICATION WIRING IS SECURE AND PROPERLY CONNECTED
<input type="checkbox"/>	<input type="checkbox"/>	<input type="checkbox"/>	<input type="checkbox"/>	CHECK DC POWER SUPPLY CONNECTION
<input type="checkbox"/>	<input type="checkbox"/>	<input type="checkbox"/>	<input type="checkbox"/>	CHECK CONTROLLER BOARD CONNECTORS ARE SECURELY AND PROPERLY INSTALLED.
<input type="checkbox"/>	<input type="checkbox"/>	<input type="checkbox"/>	<input type="checkbox"/>	CHECK BASSI CONTROLLER BOARD CONNECTORS ARE SECURELY AND PROPERLY INSTALLED.
<input type="checkbox"/>	<input type="checkbox"/>	<input type="checkbox"/>	<input type="checkbox"/>	FRONT PANEL LEDs WORK PROPERLY
<input type="checkbox"/>	<input type="checkbox"/>	<input type="checkbox"/>	<input type="checkbox"/>	DISPLAY IS FULLY OPERATIONAL
<input type="checkbox"/>	<input type="checkbox"/>	<input type="checkbox"/>	<input type="checkbox"/>	ALL FRONT PANEL CONTROL BUTTONS ARE FUNCTIONAL
<input type="checkbox"/>	<input type="checkbox"/>	<input type="checkbox"/>	<input type="checkbox"/>	LATEST APPLICATION CODE HAS BEEN LOADED
<input type="checkbox"/>	<input type="checkbox"/>	<input type="checkbox"/>	<input type="checkbox"/>	ALL SCREWS AND WASHERS PROPERLY INSTALLED ON DOOR AND BACK PANEL
<input type="checkbox"/>	<input type="checkbox"/>	<input type="checkbox"/>	<input type="checkbox"/>	VERIFY DVS CHARGES PROPERLY WHEN CONNECTED TO VEHICLE
<input type="checkbox"/>	<input type="checkbox"/>	<input type="checkbox"/>	<input type="checkbox"/>	ALL HIGH CURRENT CABLES IN CHARGING PATH ARE SECURELY FASTENED

SYSTEM CHECKED BY – NAME / SIGNATURE	/	DATE:	
CUSTOMER / LOCATION	/	DATE:	