



Webasto Go Mobile Charger User Guide



SAVE THESE INSTRUCTIONS

This manual contains important instructions for the Webasto Go Mobile Charger that should be followed during installation, operation, and maintenance of the product.

A NOTE ON CUSTOMER SUPPORT

Please have your serial number ready

when contacting customer support.

Webasto Charging Systems, Inc.
1333 S. Mayflower Ave.
Monrovia, CA 91016
USA

+1 (888) 833-2148
evscs@webasto.com

TABLE OF CONTENTS

- Section 1 INTRODUCTION 5**
 - SYMBOL USAGE 6
 - ABOUT YOUR WEBASTO GO MOBILE CHARGER 7
 - CHARGER COMPONENTS 10
 - SPECIFICATIONS 11
- Section 2 USING YOUR WEBASTO GO MOBILE CHARGER..... 13**
 - KNOW YOUR INDICATOR LIGHTS 14
 - CHARGING YOUR VEHICLE 15
 - A NOTE ON AUTO-RESTART 16
 - CARE INSTRUCTIONS 16
- Section 3 TROUBLESHOOTING 17**
 - TROUBLESHOOTING GUIDE 18
- APPENDIX 21**
 - INSTALLING THE WALL HANGER 22
 - WALL HANGER MOUNTING INSTRUCTION..... 22
 - HIGH VOLTAGE WARNING 23
 - STATE OF CALIFORNIA PROPOSITION 65 WARNINGS 24
 - FCC INFORMATION..... 24
 - SAFETY FEATURES 25
- INDEX..... 26**

Section 1

INTRODUCTION

SYMBOL USAGE

DANGER  Indicates information about safety practices which, if not followed, may result in serious injury or death.

DANGER  Risk of electric shock – Parts inside this product are a risk of shock to persons.

WARNING  Indicates information about safety practices which, if not followed, could result in personal injury or are necessary to prevent fire or equipment overheating.



Do not operate the Webasto Go Mobile Charger on an ungrounded power grid (e.g. IT networks). Only operate the Webasto Go Mobile Charger on grounded power grids.



Operating the charger at altitudes higher than 13,123 ft (4,000 m) above sea level is not recommended.

NOTE  Indicates helpful information for installation or usage, but does not contain personnel or equipment safety-related information.

ABOUT YOUR WEBASTO GO MOBILE CHARGER

The Webasto Go Mobile Charger is an easy-to-use, compact portable power supply for your electric vehicle. The charger supplies and manages AC power to your electric vehicle and is compatible with a variety of battery electric vehicles and plug-in hybrids.

The charger operates from a 120 - 240 VAC (Single Phase) 50 - 60 Hz power source.

Key Features include:

- Compact portable design
- Overheating protection
- Quick-read status indicators
- Multiple adapters available for versatile usage in a variety of locations
- Overvoltage protection

WARNING



This product must be grounded. If it should malfunction or break down, grounding provides a path of least resistance for electric current to reduce the risk of electric shock. This product is equipped with an adapter having an equipment grounding conductor and a grounding plug. The plug must be inserted into an appropriate outlet that is properly installed and grounded in accordance with all local codes and ordinances.

WARNING



Improper connection of the electrical outlet grounding conductor might result in a risk of electric shock. Check with a qualified electrician if you are uncertain whether or not the electrical outlet is properly grounded. Do not modify the plug provided with the product if it does not fit in the outlet. Have a proper outlet installed by a qualified electrician.

WARNING



It is recommended that electrical outlets for use with your charger be installed by a licensed, qualified electrician. To avoid serious injury or death, installation must comply with the provisions of the National Electric Code (NEC) and all local codes. In cases of conflict between local codes and the NEC, local codes shall take precedence.

WARNING

Do NOT DROP the control box or coupler.

Do NOT use if stored outside the temperature range specified.

WARNING

If the cable becomes separated from the control box or the charger coupler, DO NOT ATTEMPT TO REPAIR THE CABLE YOURSELF. Contact your local Webasto dealer for assistance.

WARNING

When using your Webasto Go Mobile Charger, basic precautions should always be followed, including the following:

- See the warnings on the charger cord label. Read the warnings before operating the product for the first time. Read all instructions in this guide before using this product.
- Never use the charger with an extension cord.
- Do not plug into worn or severely degraded plugs.
- Shock hazard – be sure the plug is fully inserted into the wall outlet so there are no exposed blade surfaces.
- Children should be supervised when in the vicinity of the charger while plugged in.
- Do not put insert fingers into the electric charge coupler.
- To reduce the risk of fire, only connect the charger to a circuit with 40 amps maximum branch circuit overcurrent protection in accordance with NEC and local electrical code.
- Do not use in a commercial garage classified for internal combustion engine vehicles due to vapors of flammable liquids (gasoline) being present.

CAUTION



CAUTION: Do not connect or disconnect the adapter from the control box while it is in use or charging, i.e., the adapter plug is connected to the power outlet or the vehicle connector coupler is engaged to a vehicle inlet.

CAUTION: Do not operate the charger in a temperature outside its operation range of -22°F to +122°F (-30°C to +50°C).

CAUTION: Store the charger in a clean dry place in a temperature range between of -22°F to +185°F (-30°C to 85°C).

WARNING



WARNING: Do not plug the charger into an electrical outlet submerged in water or covered in snow.

WARNING: Do not use the charger during a severe rain, snow or an electrical storm.

WARNING: Avoid moisture, water, snow and foreign objects at all times.

NOTE



This product will not charge and will give a fault indication if ground is not present. Do not replace the plug with retrofit component – there are critical safety devices in the plug, and the device will not operate if it is replaced. Do not modify. This charger contains no user modifiable/repairable parts, even for experts. Keep the charger/charge cable inside when not in use (out of the elements / inside the garage is acceptable). Do not use any third party adapters, as this can lead to a fire. Use only plugs offered from Webasto with an approved outlet. Do not unplug adapters while charging or while charger is plugged into the wall. The outlet must be in good condition and meet up-to-date NEC code. Make sure cable is completely unwound before charging.

CHARGER COMPONENTS



Mobile Charger

Release Button



SAE Charger Coupler
(North America)



IEC Charger Coupler
(Europe)

Your Webasto Go Mobile Charger comes standard with two adapters: one high power and one low power. Please refer to your vehicle owner's manual for details on included and available adapters and accessories.

SPECIFICATIONS

Charger model:	SAE (North America)	IEC (Europe)
Voltage:	120-240 VAC	230 VAC
Maximum current:	32 amps max continuous	32 amps max continuous
Frequency:	60 Hz	50 Hz
Power draw at Idle:	< 2 watts	< 2 watts
During charging:	< 4 watts	< 4 watts
Cable length:	Approximately 20 ft. (6.1 m)	Approximately 20 ft. (6.1 m)
Weight:	8.6 lb. (3.9 kg)	9.2 lb. (4.2 kg)
Temperature – operating:	-22°F to +122°F (-30°C to +50°C)	-22°F to +122°F (-30°C to +50°C)
Temperature – storage:	-22°F to +185°F (-30°C to +85°C)	-22°F to +185°F (-30°C to +85°C)
CCID environmental rating:	IP67 (watertight)	IP67 (watertight)
Ventilation:	Not required	Not required

Specifications are subject to change without notice.

Section 2

**USING YOUR
WEBASTO GO
MOBILE CHARGER**

KNOW YOUR INDICATOR LIGHTS

The Indicator light on your charger is the first thing you will notice when you are about to plug or unplug your vehicle. Before getting started, here is a simple explanation of the indicators.

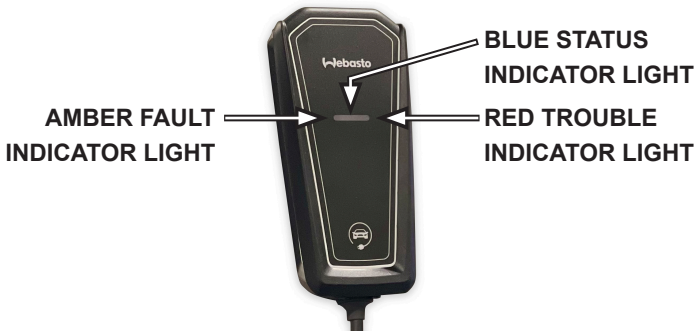

AMBER — FAULT

The AMBER FAULT Indicator illuminates to show the charger is rebooting after an error. Refer to the Troubleshooting Guide in Section 3 for more information.

BLUE — STATUS

When plugged into the wall outlet, the BLUE STATUS Indicator illuminates to show the charger is ready to use. During charging, the BLUE STATUS indicator pulses ON and OFF every two seconds. Refer to the Troubleshooting Guide in Section 3 for more information.

RED — TROUBLE

The RED TROUBLE Indicator illuminates when the charger detects an error. If the RED TROUBLE Indicator illuminates, the charger will not deliver power to the vehicle. The error must be corrected before a charging cycle can begin or continue. Refer to the Troubleshooting Guide in Section 3 for more information.

NOTE



The following indicates a normal startup safety check.

1. When first plugged into a wall socket, the AMBER, BLUE and RED indicators blink once.
2. Then the BLUE Indicator turns ON, followed by a blink of the RED indicator.
3. Lastly, the BLUE indicator turns OFF, then ON again.

This cycle will happen twice if a different adapter is used from previous charge.

CHARGING YOUR VEHICLE

1. Make sure the vehicle is in park (P).
2. Insert the adapter firmly into the control box. Then firmly insert the other end of the adapter into the appropriate wall outlet.
NOTE: You will hear an audible “click” when the adapter is correctly inserted into the control box – make sure the adapter is fully inserted and flush with the control box before inserting the other end into the wall outlet. Otherwise, it will trigger a fault or cause a longer charge session. To remove the adapter, firmly take hold of the adapter by the plug and pull it firmly away from the control box.
3. When the wall plug is inserted the AMBER, BLUE and RED indicators will blink once. Then the BLUE Indicator turns ON, followed by a blink of the RED indicator. Lastly, the BLUE indicator turns OFF, then ON again. If you switch adapters between charges, this startup system check will occur twice.
4. Plug the coupler into your vehicle’s charging inlet.
 - a. SAE: When coupler is fully inserted there will be an audible clicking sound.
 - b. IEC: The coupler will lock in place once it is fully inserted.

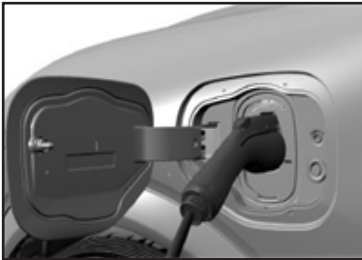

CAUTION: The control box must be fully supported before plugging coupler into the vehicle’s charging inlet.

5. When charging begins, the BLUE STATUS Indicator pulses ON and OFF approximately every two seconds.
6. When charging ends, the BLUE STATUS Indicator illuminates solid blue.
7. To disconnect the coupler from the vehicle charge port:
 - a. SAE: Press the release button on the coupler, then pull the coupler away from the vehicle.
 - b. IEC: Press the vehicle’s Cord Unlock Button, then pull the coupler way from the vehicle.

NOTE

To safely discontinue charging at any time, follow the disconnect instructions in Step 7. Charging will automatically and safely stop. The BLUE STATUS Indicator remains ON (without blinking) when the coupler is removed.

NOTE

When plugging the charger into an unfamiliar wall outlet, it is good practice to take few minutes to observe the charging process and confirm it is supplying the expected AC charging power before leaving the charger unattended.

The RED TROUBLE Indicator illuminates if it is not charging. The unit will turn OFF if a breaker or infrastructure GFI is tripped.

For more information about how to charge your vehicle, including charge settings and scheduling, refer to the vehicle owner's manual.

A NOTE ON AUTO-RESTART

The Auto-Restart feature helps to ensure that your vehicle is charged and ready for use when needed. A charge may be interrupted if an error is detected. Charging resumes once the error is no longer detected. The RED TROUBLE Indicator illuminates during an error condition.

The exception to immediate Auto-Restart is when the interruption is due to a ground fault circuit interruption (GFI/GFCI). The charger will attempt to restart 15 minutes after this happens. After a fourth attempt to restart, the charger shuts down and the RED TROUBLE Indicator stays ON.

If the fault persists, do not continue to try to charge your vehicle. Contact Webasto Customer Support (see page 3).

CARE INSTRUCTIONS

Do not use hard cleaners or solvents as this may damage your Webasto Go charger. Do not kink or place undue stress on the charger cables. If the charger overheats, bring it out of direct sunlight.

Section 3

TROUBLESHOOTING

TROUBLESHOOTING GUIDE:

Please refer to this Troubleshooting Guide for possible solutions to common errors or difficulties with charging your vehicle using your mobile charger.

NOTE



Do not attempt to repair or service the charger yourself. There are no user serviceable parts inside this product.

A RED TROUBLE Indicator may be triggered by several sources including the charger, the utility service, or the vehicle. See the Troubleshooting tips below.

The RED TROUBLE Indicator turns ON when the charger detects an error, whether it is connected to your vehicle or not. When the RED TROUBLE Indicator is ON, the charger will not deliver power to the vehicle. The error must be corrected before charging begins or resumes.

CHARGER MODE	AMBER INDICATOR	BLUE INDICATOR	RED INDICATOR	MODE EXPLANATION	TROUBLESHOOTING ACTION
UNPOWERED	OFF	OFF	OFF	THE MOBILE CHARGER IS NOT POWERED. IF LED INDICATORS ARE OFF AFTER PLUGGING THE ADAPTER INTO THE OUTLET, THERE MAY BE NO POWER FROM THE WALL OUTLET.	MAKE SURE THE OUTLET IS OPERATIONAL AND THE CIRCUIT BREAKER IS IN THE 'ON' POSITION. TRY USING ANOTHER OUTLET. ENSURE ADAPTER IS FULLY INSERTED. ENSURE THE PLUG IS NOT SEVERELY DEGRADED. IF THE ERROR PERSISTS, CONTACT WEBASTO CUSTOMER SUPPORT.
CHARGING	OFF	PULSING	OFF	THE MOBILE CHARGER IS SUCCESSFULLY CHARGING.	NO ACTION REQUIRED.
STANDBY	OFF	ON	OFF	THE MOBILE CHARGER IS POWERED AND READY TO CHARGE. THE MOBILE CHARGER IS NOT CHARGING THE VEHICLE.	IF YOU EXPECT THE MOBILE CHARGER TO BE CHARGING THE VEHICLE, ENSURE THE VEHICLE COUPLER IS PROPERLY INSERTED INTO THE VEHICLE. CHECK AND ADJUST YOUR CHARGING TIME PREFERENCES IN SYNC. IF THE VEHICLE IS STILL NOT CHARGING, CONTACT WEBASTO CUSTOMER SUPPORT.
REBOOTING	ON	ON	ON	THE MOBILE CHARGER IS AUTOMATICALLY RECOVERING AFTER ENCOUNTERING AN ERROR.	WAIT FOR THE MOBILE CHARGER TO RETURN TO STANDBY. IF THE MOBILE CHARGER CYCLES FOR MORE THAN 2-3 MINUTES, UNPLUG THE VEHICLE COUPLER. UNPLUG AND REPLUG IN THE ADAPTER. IF THE ISSUE PERSISTS, CONTACT WEBASTO CUSTOMER SUPPORT.

CHARGER MODE	AMBER INDICATOR	BLUE INDICATOR	RED INDICATOR	MODE EXPLANATION	TROUBLESHOOTING ACTION
CHARGING REDUCED	ON	PULSING	OFF	THE MOBILE CHARGER IS CHARGING AT A REDUCED RATE DUE TO OVERHEATING.	ENSURE THE ADAPTER AND CONTROL BOX ARE PROPERLY CONNECTED. DISCONNECT, THEN RECONNECT THE ADAPTER. IF THE MOBILE CHARGER IS WARM OR IN A HOT ENVIRONMENT, TRY CHARGING IN A COOLER AREA. TRY A DIFFERENT OUTLET. TRY A DIFFERENT ADAPTER IF YOU HAVE ONE AVAILABLE. IF THE ERROR PERSISTS, CONTACT WEBASTO CUSTOMER SUPPORT.
CHARGING REDUCED (AC PLUG OR WALL OUTLET)	1 FLASH	PULSING	OFF	THE MOBILE CHARGER IS CHARGING AT A REDUCED RATE DUE TO OVERHEATING OF THE ADAPTER OR THE WALL OUTLET.	ENSURE THE ADAPTER AND CONTROL BOX ARE PROPERLY CONNECTED. DISCONNECT, THEN RECONNECT THE ADAPTER. IF THE MOBILE CHARGER IS WARM OR IN A HOT ENVIRONMENT, TRY CHARGING IN A COOLER AREA. TRY A DIFFERENT OUTLET. TRY A DIFFERENT ADAPTER IF YOU HAVE ONE AVAILABLE. IF THE ERROR PERSISTS, CONTACT WEBASTO CUSTOMER SUPPORT.
USER TROUBLE-SHOOTING	ON	OFF	OFF	THE MOBILE CHARGER HAS ENCOUNTERED A FAULT THAT REQUIRES TROUBLESHOOTING.	ENSURE THE ADAPTER AND CONTROL BOX ARE PROPERLY CONNECTED. DISCONNECT, THEN RECONNECT THE ADAPTER. IF THE MOBILE CHARGER IS WARM OR IN A HOT ENVIRONMENT, TRY CHARGING IN A COOLER AREA. TRY A DIFFERENT OUTLET. TRY A DIFFERENT ADAPTER IF YOU HAVE ONE AVAILABLE. IF THE ERROR PERSISTS, CONTACT WEBASTO CUSTOMER SUPPORT.
NON-RECOVERABLE FAULT	OFF	OFF	ON	THERE IS AN INTERNAL FAULT IN THE MOBILE CHARGER THAT CANNOT BE RECOVERED	TRY A DIFFERENT ADAPTER IF YOU HAVE ONE AVAILABLE. IF ERROR PERSISTS, CONTACT WEBASTO CUSTOMER SUPPORT.
NON-RECOVERABLE FAULT (ADAPTER)	OFF	OFF	1 FLASH	THERE IS AN INTERNAL FAULT IN THE ADAPTER THAT CANNOT BE RECOVERED.	TRY USING ANOTHER ADAPTER IF YOU HAVE ONE AVAILABLE. IF NOT, CONTACT WEBASTO CUSTOMER SUPPORT ABOUT OBTAINING A REPLACEMENT. IF YOUR WARRANTY HAS EXPIRED, YOU CAN ORDER A REPLACEMENT FROM YOUR WEBASTO CUSTOMER SUPPORT.
GROUND LEAKAGE FAULT	OFF	OFF	PULSING	ELECTRICAL CURRENT IS LEAKING THROUGH A POTENTIALLY UNSAFE PATH.	POTENTIAL SHOCK HAZARD — IMMEDIATELY TURN OFF CIRCUIT BREAKER FOR THE OUTLET WITHIN HOME. DISCONTINUE USE. CONTACT WEBASTO CUSTOMER SUPPORT ABOUT OBTAINING A REPLACEMENT.

APPENDIX

INSTALLING THE WALL HANGER

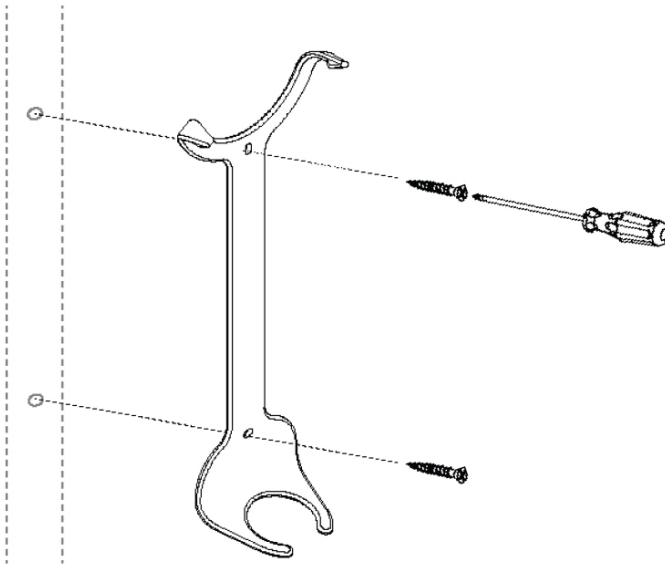

WALL HANGER MOUNTING INSTRUCTION

1. Choose a location to install the wall hanger.

The wall hanger should be located close to a wall stud, close to the wall outlet, and close to your vehicle's charge receptacle.

NOTE: Drywall and masonry wall installations require the use of appropriate fasteners.

2. Measure up approximately 8 inches from the desired receptacle and mark the location. Before drilling holes, it is recommended to verify the control box fits correctly in the hanger after it is plugged in.
3. Drill the preferred mounting holes through the back of the wall hanger using a 7/32-inch drill bit.
4. Using a Phillips screwdriver, tighten the screws for the wall hanger.

HIGH VOLTAGE WARNING

DANGER  High voltage is present in your electric meter housing and power distribution service panel. Contact with high voltage can cause death or serious personal injury.

DANGER  Risk of electric shock – Parts inside this product have a risk of shocking persons.

WARNING  DO NOT operate your charger with a damaged adapter, cable, charger coupler, or control box. Visually inspect the cable, charge coupler and charger module for damage before each use. Do not operate if any visual damage is apparent anywhere, then contact Webasto Customer Support (page 3).

WARNING  ALWAYS position the charger cable so it will not be driven over, stepped on, tripped over, damaged or stressed. To prevent personal injury and damage to the charger, ALWAYS stow the charger on hanger or in the stowage bag after use.

WARNING  Use the charger only to supply power to electric vehicles equipped with an SAE J1772 or IEC 62196-2 compliant vehicle receptacle. For more information, refer to the vehicle owner's manual.

NOTE  Disconnect the charger from the wall outlet before cleaning it. To clean the charger, wipe it with a clean cloth dampened with water or a mild detergent solution suitable for use on automobile paint. Do not use chemicals or solvents. Do not submerge the charger in any type of fluid.

STATE OF CALIFORNIA PROPOSITION 65 WARNINGS

WARNING



This product contains a chemical known to the State of California to cause cancer or birth defects or other reproductive harm.

FCC INFORMATION

This device complies with Part 15 of the FCC Rules. Operation is subject to the following two conditions:

- This device may not cause harmful interference.
- This device must accept any interference received, including interference that may cause undesired operation.

This product has been designed to protect against Radio Frequency Interference (RFI). However, there are some instances where high-powered radio signals or nearby RF- producing equipment could affect operation.

If you suspect your charger is receiving interference, take the following steps before contacting Customer Support for service:

1. Relocate away from electrical appliances or equipment during charging.
2. Turn off nearby electrical appliances or equipment during charging.

Important! Changes or modifications to this product by anyone other than an authorized service provider will void FCC compliance and the product will not be serviceable.

SAFETY FEATURES

The charger is designed with your safety as the highest priority and includes the following safety features to protect against the risk of electric shock:

- **Service Ground Check:** The charger constantly checks for the presence of a service ground connection. If the service ground ever fails, the charger RED TROUBLE Indicator turns ON and shuts down power to the vehicle.
- **Thermal Event Sensor:** The charger module senses out-of-ordinary thermal events and will decrease charging current or shut the unit down if required.
- **GFCI Protection:** The charger is equipped with a ground fault circuit interruption (GFI/GFCI) reaction system to protect against electric shock. If the charger module detects an output ground fault, it will shut down power to the output cable and illuminate the RED TROUBLE indicator.
- **Insulation:** The charger module, adapter, cable assembly, and charge coupler are completely insulated (no exposed live parts) to protect against electric shock.
- **Unintentional Disconnection:** The charge coupler is designed to minimize unintentional disconnection. A pilot signal wire in the cable and charge coupler eliminates the possibility of electric shock when not connected to a vehicle or if an unintended disconnect occurs during a charge. Disconnection during charging is safe.

INDEX

A		O	
auto restart	16	output ground	25
B		outlet	7, 8, 9, 14, 15, 16, 18, 19, 23
blue status indicator	14, 15, 16	P	
C		pilot signal wire	25
charge coupler	8, 23, 25	R	
circuit breaker	18, 19	receptacle	22, 23
components	10	RED TROUBLE indicator	14, 16, 18, 25
customer support.....	3, 24	release button	10, 15
E		S	
electric shock	6, 7, 23, 25	SAE J1772	23
environmental rating	11	safety features	25
F		serial number	3
features	7, 25	service ground	25
G		STATUS indicator	7, 14, 15
GFI/GFCI	16, 25	T	
H		temperature	8, 9, 11
hanger	22, 23	TROUBLE indicator	14, 16, 18, 25
I		W	
IEC 62196-2	23	warranty	19
insulated 2	5	weight	11
indicator light	14		

Webasto Charging Systems, Inc.
1333 S. Mayflower Ave., Suite 100
Monrovia, CA 91016

Corporate headquarters:

Friedrichshafener Str. 9
82205 Gilching
Germany

Identification No. 5911743-A-01 • 02/2022 • © Webasto Charging Systems, Inc.